

# Classic

## Combi exit/route-light

### Technical specifications

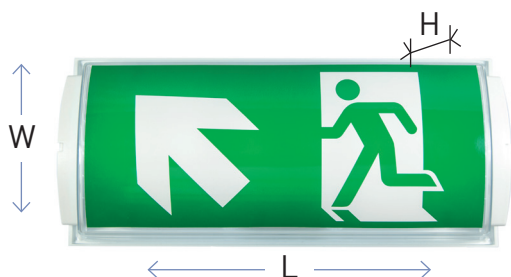

- LED
- Low effect consume
- Environment friendly battery (NiMh(HT))
- 1 and 3 hour battery
- Controlled and optimized charging
- EN-60598-2-22/EN-62034

- Easy installation
- Easy battery exchange
- Additionally double sided dome
- Pot. free outlet option
- Battery lifetime 4 years
- LED lifetime 5-10 years
- **L: 325mm W:145mm H: 77mm**

- Special versions:**
- Luminaires with Dali
  - Dimmable luminaire

Joint	Exit	Route	
Effect consume	1,5W	0,5W	
Lightsource	LED	LED	
IP – class	IP65	IP65	
Reading distance	24 m	-	
Flux	142lm	178lm	
Ambient temp.	-20°C → 25°C	-20°C → 25°C	
1 lux installed leading light			
H (m):	2,4	2,75	3,0
D (m):	10,5	12	13,2



Centralized	
<b>24 V</b>	24V AC/DC
<b>230 V</b>	230V AC/DC



Decentralized	
Self test	X
Communication	Dali
Alarm output	Potfree NO/NC
Battery capacity	1 / 3 hour(s)
Battery type	NiMH (High temp)

### This emergency Light is supplied with Test levels according to EN-62034

"The light source is under constant surveillance during normal operation"

#### Manual TEST:

Functional test, in short version, can be activated by a quick push on the \*TEST – button. Then it will be running for 10-15 sek.

Duration Test, will be activated, by pushing the \*TEST - button for 5-10 sek.

\*In some products, the TEST – button will be replaced by a magnetic sensor. Then you need a magnetic TEST – equipment to activate all the manual tests!

#### Functional TEST

The test starts automatically once per week and lasts for 5 minutes, checking if all "vital" parts are functioning.

#### Duration TEST

The test starts automatically once per every 3 months and lasts for 1 hour. The test checks that the battery capacity is sufficient. Duration test can also be started manually.

All tests will be stopped if the battery capacity is too low or if the "Mains/net" falls out. Red or Yellow indicator will illuminate in case there is some internal failure.

#### Signal indicators

Yellow	Green	Red	
○	●	○	OK
○	○	○	NO charging
○	●	○	Maintenance charging
●	●	○	Failure on battery
○	●	●	Failure on light source
●	●	●	Battery- and light source failure
●	●	●	Test running

## Technical specifications

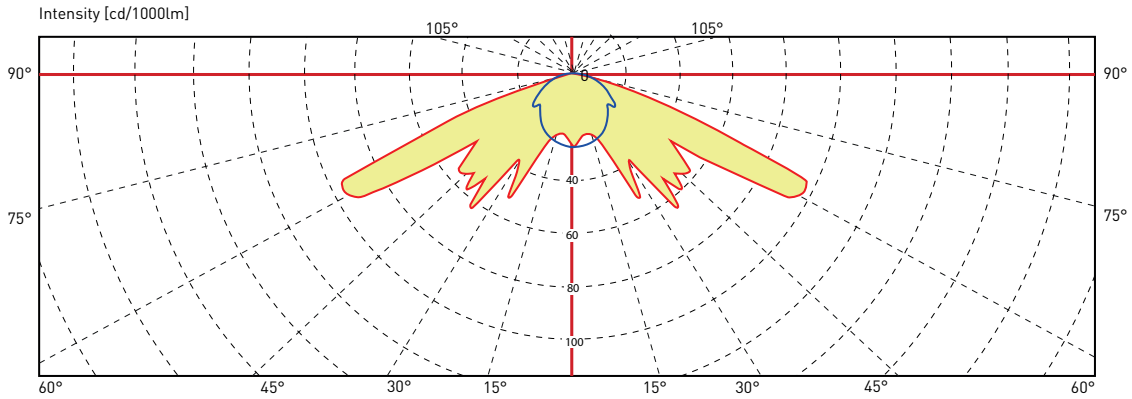

### Escape route

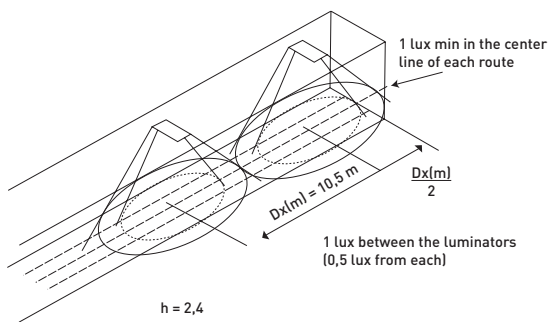

### Escape route

The escape route has to be projected such as the center-line has a min. illumination level of 1 lux. The contrast has to be max. 40:1. The center line is defined as half of the total wide of the escape route.

### Antipanic area

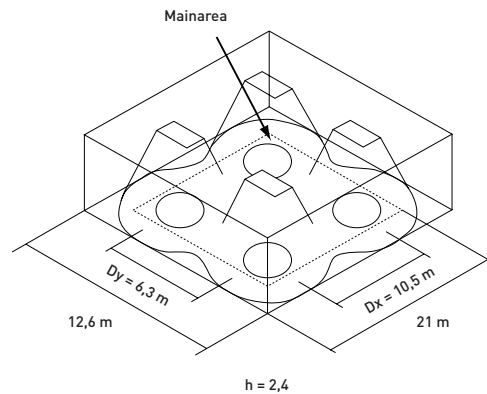

### Antipanic area

The areas, where it probably are people gathered in an emergency situation, shall have a illumination level of at least 0.5lux.

#### 1 lux installed routelight - Escape Route

H (m):	2,4	2,75	3	3,5	4	4,5	5	5,5
Dx(m):	10,5	12	13,2	13,8	14,6	15,6	17,4	12

Dx(m) max = 17,4m, H = 5m

#### 0,5 lux installed routelight - Antipanic Area

H (m)	2,4	1,75	3	3,5	4	4,5	5	5,5	6	6,5
Dx (m)	10,5	12	13,2	13,8	14,6	15,6	17,4	19	20	22
Dy (m):	6,3	6,6	7,1	8,2	8	9	10	8,4	7,5	6,8

Dx(m) max = 22m, H = 6,5m

Dy(m) max = 10m, H = 5m